

TYPICAL SLUNG DRAINAGE PIPE DETAILS

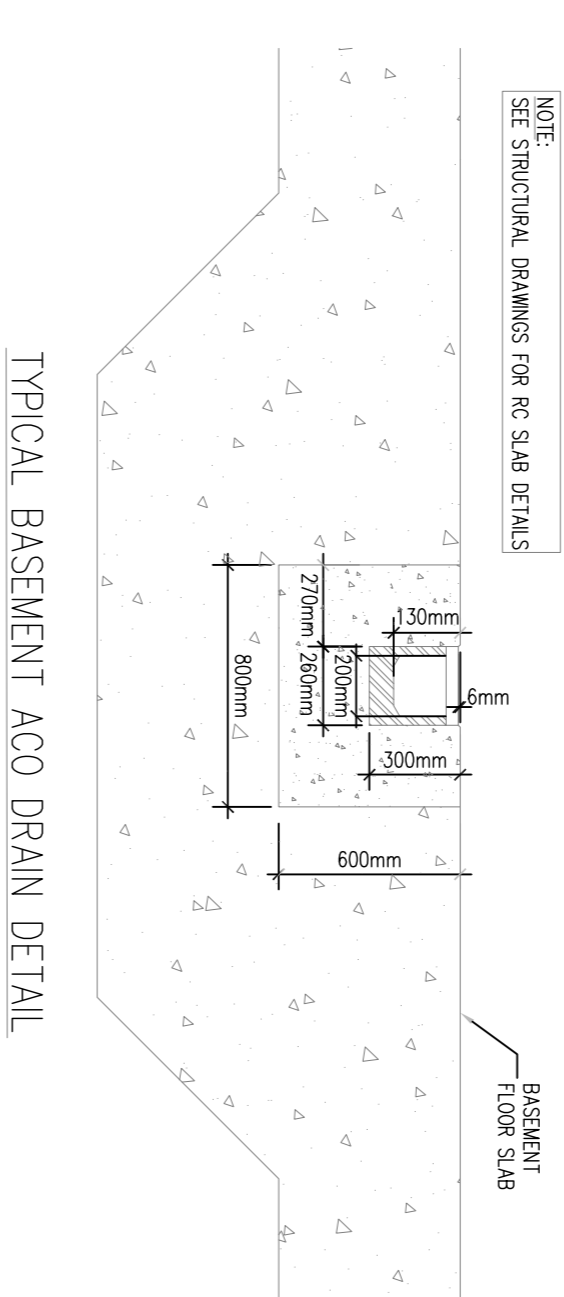

TYPICAL SECTION THROUGH SLUNG DRAINAGE

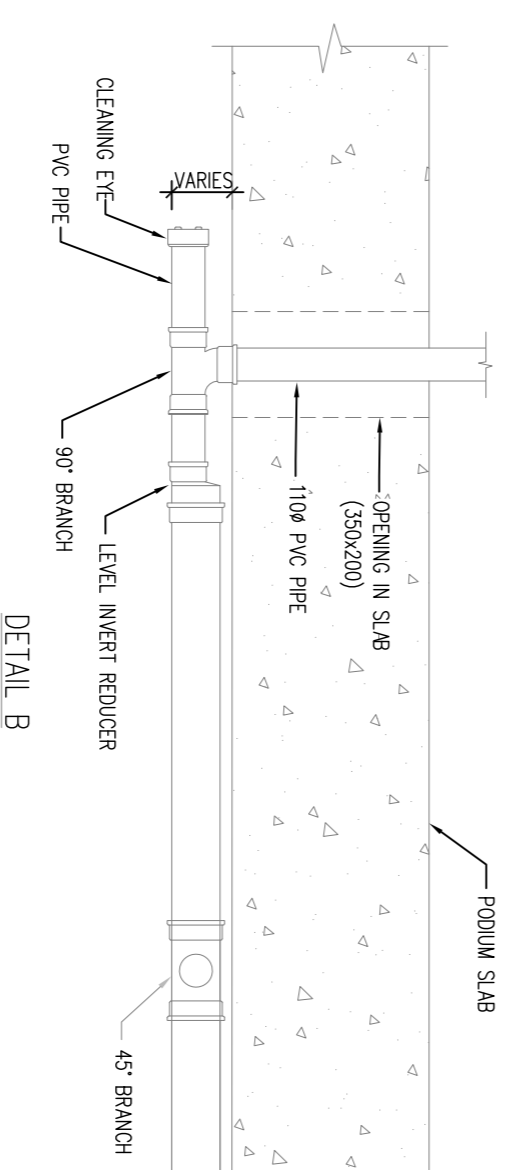

DIMENSIONS

Figure dimensions only to be taken from this drawing. All dimensions to be checked on site. Architects to be informed immediately of any discrepancies before work proceeds.

© COPYRIGHT

This drawing and any design hereon is copyright of JOR Consulting Engineers and must not be reproduced in whole or in part without their express written consent.

NOTES:

1. ALL WORKS TO BE UNDERTAKEN IN ACCORDANCE WITH THE S.I. STANDARD SPECIFICATION FOR WATER/CEMENT RATIO OF 0.65 AND SLUMP OF 100-120MM.
2. RECOMMENDATIONS FOR SITE DEVELOPMENT.
3. REFER TO IRISH WATER MANUALS.
4. REFER TO IRISH WATER MANUALS.
5. REFER TO IRISH WATER MANUALS.
6. REFER TO IRISH WATER MANUALS.
7. REFER TO IRISH WATER MANUALS.
8. REFER TO IRISH WATER MANUALS.

REV	DATE	DETAILS
P01	22/07/22	Issued for Pre-Planning
P01	14/03/22	Issued for Pre-Planning

JOR
Joseph O'Reilly
Consulting Civil & Structural Engineers

Tel: 046 9077092 Fax: 046 9077932
Email: mail@jor.ie Web: www.jor.ie

Unit 1, St. Theresa's Place, Flowerhill, Navan, Co. Meath

CLIENT
Scanlon Limited

PROJECT
Daneswell Place LRD Planning Application
Daneswell Place,
Former Printworks Smurfit Site,
Botanic Road, Glasnevin, Dublin 9

TITLE		ISSUED FOR	
Typical Drainage Details - Basement		P L A N N I N G	
SCALE	DATE CREATED	DRAWN BY:	DOB
As Shown @ A1	OCTOBER 2020	CHECKED BY:	JOR
JOB No.	DRAWING No.	REV	
J17-117	020	P01	